

XP680A(2VP78FE/P-A)  
GASOLINE ENGINE

# OPERATOR'S MANUAL

**⚠ WARNING**

Read this manual carefully before operation.  
This manual includes important guidance for safety operation.



This Manual contains important safety information and instructions for operating this engine. **PLEASE READ THIS MANUAL CAREFULLY.** Failure to do so could result in property damage and/or personal INJURY/DEATH.

Provide this manual to any operator of this engine. This manual should be considered as a permanent part of your engine and should remain with it when you sell it.

All pictures&figures are only one example of series generator. It shall be only for reference and perhaps there will be difference between pictures & figures and physical products.

All information in this publication is based on the latest product information available at the time of printing. We reserve the right to change, alter and/or improve the product and this document at any time without notice and without incurring any obligation.

No part of this publication shall be reproduced without written permission.

Write down the engine's serial number and purchase information. Keep this manual and the receipt for future reference.

Model:

---

Serial number:

---

Date of purchase:

---

# Contents

<b>I. Operator safety</b> .....	<b>1</b>
1. Safety rules.....	1
<b>II. Features and Controls</b> .....	<b>5</b>
<b>III. Operating</b> .....	<b>6</b>
1. Operating checklist.....	6
2. Starting the engine.....	9
3. Stopping the engine.....	12
4. Terminal application.....	13
5. After each use.....	14
<b>IV. Maintenance</b> .....	<b>14</b>
1. Maintenance schedule.....	15
2. General maintenance.....	16
3. Idle Speed.....	21
<b>V. Trouble-shooting</b> .....	<b>22</b>
<b>VI. Storage</b> .....	<b>23</b>
<b>VII. Specification</b> .....	<b>24</b>
1. Engine Specification.....	24
2. Engine Dimension.....	25
3. Engine circuit diagram.....	26



# I. Operator safety

## 1. Safety rules



Pay attention to this safety alert symbol. Obey all safety messages that follow this symbol to avoid possible property damage, INJURY or DEATH.

Each safety message is preceded by a safety alert symbol and one of three words, DANGER, WARNING, or CAUTION.

### **DANGER**

Indicates a hazardous situation which, if not strictly complied with, will result in substantial property damage, serious injury or DEATH.

### **WARNING**

Indicates a hazardous situation which, if not strictly complied with, may result in property damage, serious injury or DEATH.

### **CAUTION**

Indicates a hazardous situation which, if not strictly complied with, could result in property damage or injury.



### **WARNING**

**READ THIS MANUAL COMPLETELY BEFORE OPERATING.**

DO NOT operate this engine until you have read ALL safety, operation, and maintenance Instructions listed in this manual.

**Failure to follow the instructions may result in property damage, INJURY or DEATH.**

The warnings and precautions discussed in this manual cannot cover all possible conditions and situations that may occur. It must be understood by the operator that common sense and caution are factors which cannot be built into this product, but must be possessed by the operator.

### **WARNING**

Unauthorized modified any part of the generator or for any unsuitable usage is allowed.

**⚠ WARNING**

Before each use, check for loose or damaged parts, signs of oil or fuel leaks, and any other condition that may affect proper operation. Repair or replace all damaged or defective parts immediately.

Locate all operating controls and safety labels.

Keep all safety guards in place and in proper working order at all times.

DO NOT allow any material to block the cooling slots.

DO NOT allow children or untrained persons to operate the engine.

DO NOT run the engine unattended. Turn off the Engine before leaving the area.



**⚠ WARNING**

**FIRE**

Operation of this engine may create sparks that can start fires around dry vegetation.

This engine may not be equipped with a spark arresting muffler. If the engine will be used around flammable materials, or on land covered with materials such as agricultural crops, forest, brush, grass, or other similar items, then an approved spark arrester must be installed.

In some area, a spark arrester is required by law. Please contact local fire agencies for laws or regulations relating to fire prevention requirements.



**⚠ WARNING**

**KICKBACK**

Rapid retraction of the starter cord will pull hand and arm towards the engine faster than you can let go.

Unintentional startup can result in accident.

**⚠ WARNING**

Read the instructions provided with the equipment that powered by this engine for any additional safety rules that should be observed in conjunction with engine startup, shutdown, operation, or protective apparel that may be needed to operate the equipment.



**⚠ WARNING**

### **HOT SURFACE**

Running engines and produce heat. Severe burns can occur when contact with hot surface.

DO NOT touch engine while operating or just after stopping. Avoid contact with hot exhaust gases.

Maintain at least three feet of clearance on all sides to ensure adequate cooling.

Combustible material can catch fire on contact. Maintain at least five feet of clearance from combustible materials.

**⚠ DANGER**

Do not tamper with the engine governed speed.

High operating speeds are dangerous and increase the risk of personal injury or damage to the equipment.

Operating at low speeds with heavy load may shorten the engine's life.



**⚠ DANGER**

### **FIRE OR EXPLOSION**

Gasoline is highly flammable and extremely explosive.

Fire or explosion can cause severe burns or death.

Keep flammable items away while handling gasoline.

Fill fuel tank outdoors and in a well-ventilated area with the engine stopped.

Always wipe off spilled fuel and wait until the fuel has dried before starting the engine.

DO NOT operate the engine with known leaks in the fuel system.

Use proper fuel storage and handling procedures. DO NOT store fuel or other flammable materials nearby.

Empty the fuel tank before storing or transporting this engine.

Keep fire extinguisher handy and be prepared if a fire starts.



**⚠ DANGER**

### **MOVING PARTS**

Moving parts can cause severe injury. Keep hands and feet away.

**DO NOT** operate engine with covers, shrouds, or guards removed.

**DO NOT** wear loose-fitting clothing, dangling drawstrings or items that could become caught. Tie up long hair and remove jewelry.

The moving parts may catch operator's hand, feet, hair or clothes such that will cause traumatic amputation or broken bones, fracture.

**NEVER** place fingers, hands, or body near the engine when it is running.



**⚠ DANGER**

### **TOXIC FUMES**

The exhaust of the engine contains carbon monoxide, an odorless, colorless, poison gas. Using engine indoors **CAN KILL YOU!**

**NEVER** use inside any building or any kind of enclosure, **EVEN IF** doors and windows are open.

Place the engine in a well-ventilated area and carefully consider wind and air currents when positioning the engine.

## II. Features and Controls

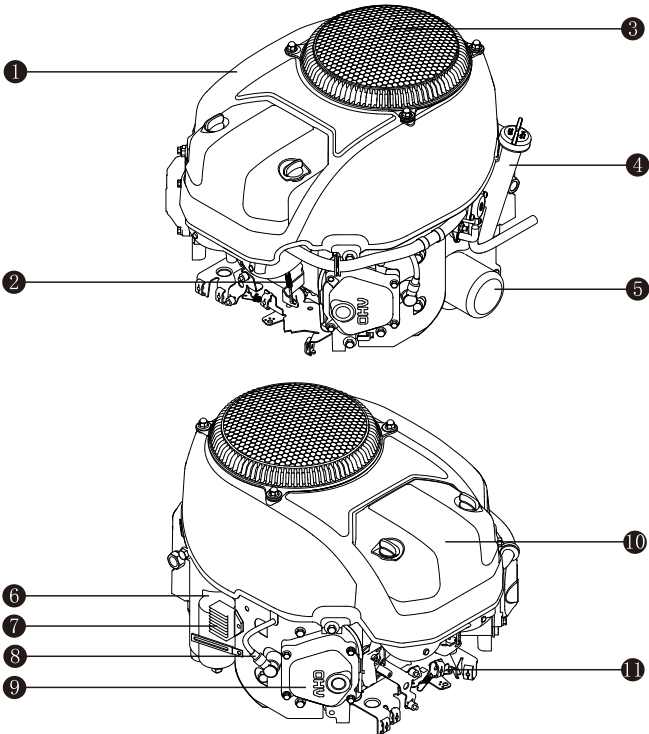

- |                   |                     |
|-------------------|---------------------|
| ① Air guide cover | ⑦ Flow regulator    |
| ② Spring          | ⑧ Ignition          |
| ③ Debris shroud   | ⑨ Cylinder head     |
| ④ Oil dipstick    | ⑩ Air filter        |
| ⑤ Oil filter      | ⑪ Governor assembly |
| ⑥ Starting motor  |                     |

### III. Operating

#### 1. Operating checklist

##### 1 Operating Location

Only use OUTSIDE and place the engine in a well-ventilated area and carefully consider wind and air currents.

Place the engine on level surface before any operation.



**⚠ DANGER**

##### **TOXIC FUMES**

The exhaust of the engine contains carbon monoxide, Using engine indoors **CAN KILL YOU!**

**NEVER** use inside any building or any kind of enclosure, **EVEN IF** doors and windows are open.

##### **High altitude**

This engine may require a high altitude carburetor kit to ensure correct operation at high altitudes. Consult the authorized local dealer for high altitude kit information if you always operate your engine at altitudes above 5,000 feet (1,500 meters).

**⚠ CAUTION**

Even with carburetor modification, engine horsepower will decrease about 3.5% for each 1,000 feet (300 meters) increase in altitude. The effect of altitude on horsepower will be greater than this if no carburetor modification is made.

**⚠ CAUTION**

Operation the engine at altitude below 5,000 feet (1,500 meters) with modified carburetor may cause the engine to overheat and result in serious engine damage.

##### 2 Operating Condition

Check for loose or damaged parts, signs of oil or fuel leaks, and any other condition that may affect proper operation. Repair or replace all damaged or defective parts immediately.

**⚠ WARNING**

Failing to correct problem(s) before operation could result in property damage, serious injury or **DEATH.**

Remove any excessive dirt or debris, especially around the muffler and recoil starter.

Refer to operating instructions of equipment that this engine powers. Do not operate this engine exceeding maximum angle of operation; see specification table.

### 3 Engine oil

Place the engine on a level surface with engine stopped.

Remove the dipstick and wipe it clean.

Insert the dipstick in the dipstick hole.

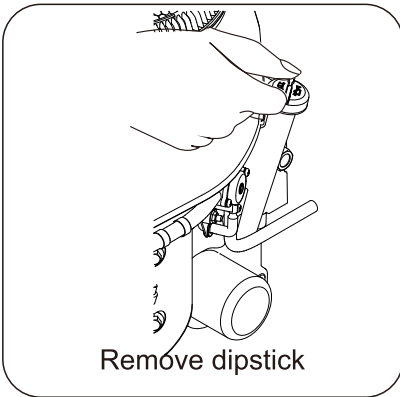

Remove the dipstick again and check oil level. Level should be between the upper and lower limit.

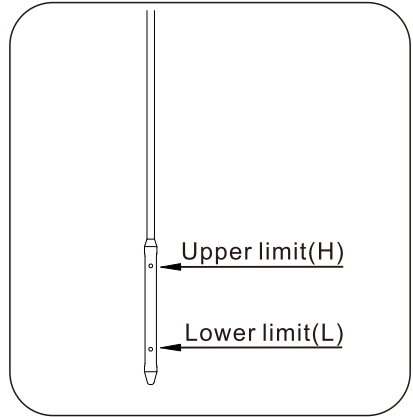

Fill to the upper limit (marked with "H") of the dipstick with the recommended oil if the oil level is low.

Re-insert the dipstick into the dipstick hole.

Refer to **add oil** instruction in **MAINTENANCE** section for more information.

**Oil capacity (rated):**  
**see parameter.**  
**(to be determined according to the dipstick scale).**

**Recommended oil trade:**  
**SAE 10W-30**

#### **⚠ WARNING**

This engine is not filled with oil before send out from the factory. Any attempt to crank or start the engine before it has been properly filled with the recommended type and amount of oil may result in engine damage and void your warranty.

## **WARNING**

Oil is a major factor affecting performance and service life. Use 4-stroke automotive detergent oil recommended in the **MAINTENANCE** section of this manual.

## **4** Engine fuel

With the engine stopped, check the fuel level. Refill the fuel tank if necessary.

## **CAUTION**

Pressure can build up in the fuel tank. Allow the engine to cool for at least two minutes before removing fuel cap. Loosen the fuel cap slowly to relieve any pressure in the tank.

Use clean, fresh, regular unleaded gasoline with a minimum octane rating of 90#.

**DO NOT** mix oil with gasoline.

Be sure not to fill above the upper limit mark. Always allow room for fuel expansion.

## **DANGER**

Do not fill the fuel tank above the upper limit. Over fill will result in engine die or damage the carbon canister (if equipped) and void your warranty.

**NEVER** use engine or carburetor cleaner products in the fuel tank or permanent damage may occur.

It is important to prevent gum deposits from forming in essential fuel system parts, such as the carburetor, fuel filter, fuel hose or tank during storage. Also, experience indicates that alcohol-blended fuels (called gasohol, ethanol or methanol) can attract moisture, which leads to separation and formation of acids during storage.

Acidic fuel can damage the fuel system of an engine while in storage. Be sure to review the instructions given in "Storage" on page 23.





## **⚠ DANGER**

### **FIRE OR EXPLOSION**

Gasoline is highly flammable and extremely explosive.

Fire or explosion can cause severe burns or death.

Keep flammable items away while handling gasoline.

Fill fuel tank outdoors and in a well-ventilated area with the engine stopped.

Always wipe off spilled fuel and wait until the fuel has dried before starting the engine.

DO NOT operate the engine with known leaks in the fuel system.

Use proper fuel storage and handling procedures. DO NOT store fuel or other flammable materials nearby.

Empty the fuel tank before storing or transporting this engine.

Keep fire extinguisher handy and be prepared if a fire starts.

Gasoline/Alcohol Blends: up to 10% alcohol, 90% unleaded gasoline by volume is approved as a fuel. Other gasoline/alcohol blends are not approved. Effects of old, stale or contaminated fuel are not warrantable.

## **⚠ CAUTION**

To minimize gum deposits in your fuel system and to insure easy starting, do not use gasoline left over from the previous season.

### **5 Equipment check**

Check the equipment powered by this engine. Review the instructions provided by the equipment manufacturer for any precautions and procedures that should be followed before start the engine.

## **⚠ WARNING**

This engine is designed and manufactured for specific applications. Do not attempt to modify the equipment or use it for any application for which it was not designed. If you have questions about specific application, ask your local dealer.

## **2. Starting the engine**

### **1**

Perform operating checklist (See page 6).

**2**

Turn the fuel switch to the **ON** position and turn the choke lever to the **OFF** position .

**3**

Adjust the throttle lever to a proper position, and then turn the start switch to start the gasoline engine.

**4**

After the gasoline engine starts, slowly turn the choke lever to the **ON** position so that the gasoline engine runs at idle for (3-5) minutes, check the operation for stability and any abnormal sound, and then adjust the opening degree of the throttle to reach the required speed.

**⚠ CAUTION**

Choke position for starting may vary from temperatures and other factors. If re-starting a warm engine, the choke should be left in ON position.

## Manual starting

(Applicable model)

**⚠ WARNING**

Check starter cord conditions before operating. Have it replaced immediately by local authorized dealer if cord is frayed.

**1**

When starting engine, grasp the recoil starter handle and pull slowly until resistance is felt. Then pull rapidly to avoid kickback.

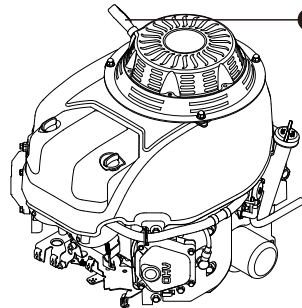

**1** Recoil starter grip

**2**

Do not allow the handle suddenly back to hit the engine. Return it gently along the resilience force direction of the starter rope to prevent damage to the starter.



**⚠ WARNING**

### **KICKBACK**

Rapid retraction of the starter cord will pull hand and arm towards the engine faster than you can let go.

Unintentional startup can result in entanglement, traumatic hurtful accident.

## **Electric starting**

Turn the key to the START position and keep moving up until the engine starts. After the engine starts, release the key and return it to the ON position.

If the starter cannot drive the engine to rotate, turn off the starter immediately. Do not attempt to start the engine again before finding the causes of the fault. Prohibit the unauthorized change of other battery for re-start.

**⚠ WARNING**

Do not continuously start the engine for more than 15 seconds at a time. If the engine fails to start, cool the starting motor for 1 minute before re-start. Otherwise, it may cause damage to the starting motor.

**⚠ CAUTION**

If engine cannot be started or shutdown after start for three times, check to ensure that the engine is placed on a horizontal surface and is filled with enough oil.

If the engine is equipped with a low oil level sensor, when the oil in the crankcase is below the minimum level, this will prevent the engine from start.

Make the oil routine inspection during the running-in. For the recommended maintenance intervals, see the section Maintenance and Servicing.

If the engine speed is raised to the speed over the starter but does not keep running (fails to start), then the engine must completely stop before start again. If when the flywheel starts to rotate automatically, the starter is still engaged, then there may be a conflict between the flywheel external gear and the starter pinions, and this may cause damage to the starter.

**1**

After a successful start, as the engine temperature rises, slowly turn the choke lever to the **ON** position. After the gasoline engine runs at idle for (3-5) minutes, if the engine is running unstably (with shake), then turn the choke lever to the **half-ON** position, and turn the choke lever to the **ON** position until the engine is running stable.

**⚠ CAUTION**

When the engine is warming up, partially open the throttle until the engine temperature rises to a certain level.

**2**

The engine can be loaded by moving the idle speed control switch to the ON position.

## Setting the engine speed

**1**

The engine speed has been set at the factory. Do not attempt adjust the engine speed with unauthorized means; otherwise, it may cause damage to the engine or personal injury.

**2**

If there are questions for the operation of the engine or other requirements, please return the engine to our authorized dealers for disposal, do not disposal by yourselves unless the user has the proper tools and machine maintenance capabilities.

## 3. Stopping the Engine

**1**

To stop the gasoline engine running at high load, first release the load, reduce the speed, move the stop lever to the "○" position after running at idle for (2-3) minutes. Pull out the spark plug to force to stop the engine if the stop switch fails.

**2**

If the gasoline engine has abnormal noise, severe vibration, serious hunting, popping and other defective phenomena during operation, emergently stop the engine. Emergency stop method: directly press the stop switch to the "○" position or pull out the spark plug.

**⚠ CAUTION**

Prohibit direct stop the engine without load released unless under abnormal condition happens !

**3**

Turn the fuel switch, if any, to the **OFF** position.

## 4. Terminal application

When the engine is electrically started, use a 12V battery with a capacity of at least 21Ah. Connect the positive electrode of the battery to the terminal of the starting motor relay, and connect the negative electrode to the gasoline bolt and screw or install the negative electrode on the conductive plane of the gasoline engine.

**⚠ CAUTION**

Prohibit connecting the negative electrode of the battery to three bolts of the mounting base of the oil fine filter.

The wiring diagram for the gasoline engine as shown in "circuit diagram" on page 26.

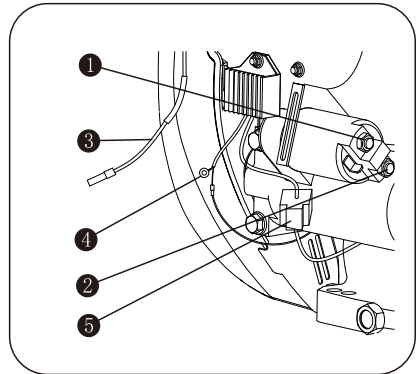

- ① Positive terminal
- ② Relay connector
- ③ Positive input line of carburetor battery valve
- ④ Flameout line
- ⑤ Positive output connector of charging coil

## 5. After each use

Please pour the fuel and the carburetor fuel out, for a long time not use, keep the surface is clean, and indoor storage.

## IV. Maintenance

It is the owner's/operator's responsibility to complete all scheduled maintenance in a timely manner. Correct any issue before operating the engine. Always follow the inspection and maintenance recommendations and schedules in this manual.

Before servicing the engine, **stop the engine**, disconnect all electric devices and battery (if equipped) and allow the engine to cool down.

**⚠ DANGER**

Accidental starts can cause severe injury or death. Remove and ground spark plug wire before performing any service.

**⚠ WARNING**

Improper maintenance or failure to correct a problem before operation can cause a malfunction and result in property damage, serious injury or DEATH.

Improper maintenance will void your warranty.

**⚠ CAUTION**

The filter element may contains PAHs, PAHs are harmful for your health. Please wear gloves for protection during air filter maintenance.

# 1. Maintenance schedule

Follow the service intervals indicated in the chart below. Service your engine more frequently when operating in adverse conditions. Contact your local service dealer for your engine or engine maintenance needs.

		Each time before use	10 hours or the first month <sup>2</sup>	50 hours or every three months <sup>2</sup>	100 hours or every six months <sup>2</sup>	300 hours or every year <sup>2</sup>
Engine oil	Inspection	√				
	Replacement		√		√	
Air filter	Inspection	√				
	Cleaning			√ <sup>3</sup>		
Spark plug	Inspection and adjustment				√	
	Replacement					√
Spark extinguisher <sup>1</sup>	Cleaning				√	
Idle speed	Inspection and adjustment					√ <sup>4</sup>
Valve clearance	Inspection and adjustment					√ <sup>4</sup>
Carbon canister <sup>1</sup>	Inspection	Every two years <sup>4</sup>				
Low permeability oil tube <sup>1</sup>	Inspection	Every two years <sup>4</sup>				
Oil tube	Inspection	Every two years <sup>4</sup>				

## NOTE:

- 1.Applicable types.
- 2.Before each season and after then (whichever comes first).
- 3.Service more frequently under severe, dusty, dirty conditions.
- 4.To be performed by knowledgeable, experienced owners or the authorized dealer.

## 2. General maintenance

### Engine oil

SAE 10W-30 is recommended for general, all-temperature use. Other viscosities shown in the chart may be used when the average temperature in your area is within the indicated range.

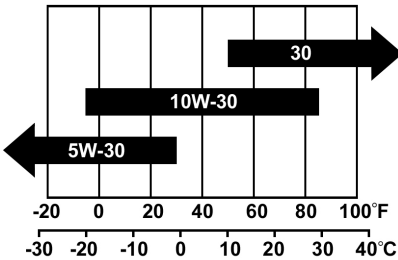

### AMBIENT TEMPERATURE

**Oil capacity (rated):**  
see parameter.

### Add oil

1. Place the engine on a level surface.
2. Remove the dipstick, and fill the oil of the recommended type.

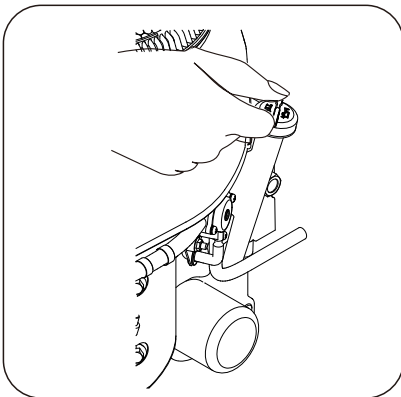

3. Remove the dipstick and check the oil filling volume which should be at the upper limit of between the upper and lower limit.

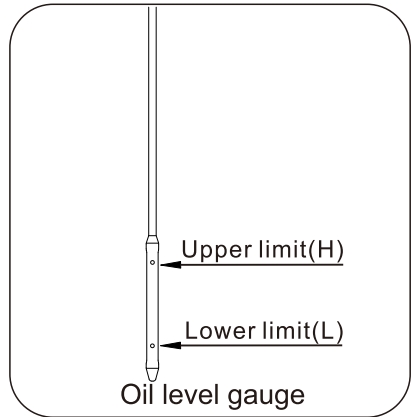

4. Completely insert the dipstick into the dipstick hole during inspection.

5. Dispose of used oil at an approved waste management facility.

### Change oil

#### **⚠ CAUTION**

Change oil when the engine is warm after operation.

When oil is changed, it is recommended to run the engine for five minutes without load and then stop the engine for oil change, which can ensure quick and complete drainage of the lubricating oil.



1. Select and place the appropriate container at the oil outlet of the gasoline engine to store the waste oil, and then unscrew the oil plug and the drain bolt and gaskets thereof.

2. When the oil is completely drained, install a new gasket on the drain bolt and re-tighten the drain bolt.

3. Place the gasoline engine levelly, and then fill the oil of the recommended grade to the upper limit of the dipstick.

4. Re-tighten the oil plug.

### **⚠ WARNING**

The engine is not filled with oil at the factory. Any operation before it has been properly filled with the recommended type and amount of oil may result in engine damage and void your warranty.

If there is oil overflowed, wipe off the spilled oil is needed. Clean your hands with soap or detergent in contact with the oil, and then rinse with water.

Please dispose the waste lubricant in the container in a manner that is compatible with the environmentally. It is recommended to put the waste lubricant in a sealed container and deliver it to the local recycling bin for treatment. Do

not directly throw it in the trash bin or pour it into the water.

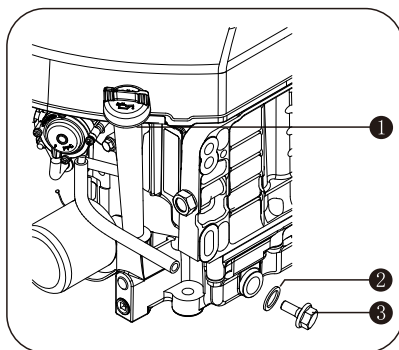

- ① Oil dipstick
- ② Drain bolt gasket
- ③ Drain bolt

### **Replacing the oil fine filter**

Drain the oil, and then re-tighten the drain bolt.

1. Remove the oil fine filter, then pour the oil into a suitable container. Put the used oil and fine filter in the appropriate place. In order to prevent the oil fine filter from deformation or damage, do not remove it with the conventional wrench; please use a special oil fine filter sleeve.

2. After cleaning the mounting base of the fine filter, clean the seal ring of a new fine filter with new oil.

3. Tighten a new oil fine filter by hand directly until the seal ring comes into contact with the mounting base, and then tighten the fine filter with the fine filter sleeve (tightening torque for oil fine filter:  $25\text{ N} \cdot \text{m} - 27\text{ N} \cdot \text{m}$ ).

4. Re-install the drain bolt and the dipstick, and then fill the recommend oil in the gasoline engine.

5. Start the engine and check for oil leaks.

6. Stop the engine, and then remove the dipstick and check whether the oil level is within the specified range. If the oil level is too low, it is required to refill the oil to the predetermined scale.

## Air filter

1. Clean area around the air filter.
2. Loosen the air filter bolt and remove cover.

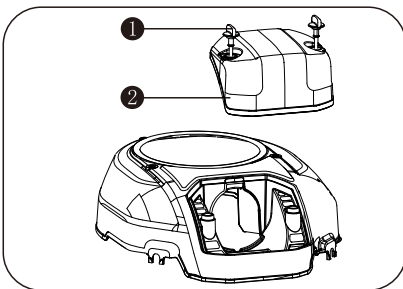

- 1 Air filter bolt
- 2 Air filter cover

3. Remove the filter element from the cover.

4. Remove the foam filter element .

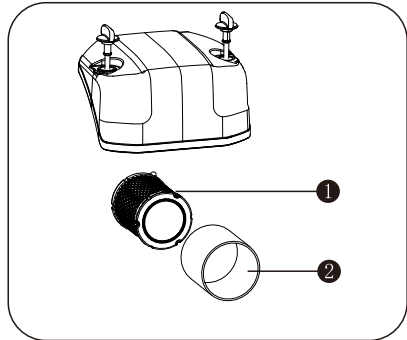

- 1 Paper filter
- 2 Foam filter

5. Remove dusty through patting the paper filter element, replace a new one if needed.

6. Rinse and dry the foam filter in water after clean with detergent, and use after naturally throughout dry.

7. Install the filter element into the cover.

8. Reinstall air filter assembly back to air housing guard and fasten it with bolt

## **⚠ CAUTION**

Do not run the engine without air filter mounting, if so, serious wear may happen to engine.

The air filter is double element (paper&foam), remove air filter cover before take out filter element.

### CAUTION

The effect of air filter is for dusty and dirty filtration, and let clean air blend with fuel to help to stable engine performance. If air filter is too dirty or dusty, it would impact air intake less than fire needed, so improper air and fuel ratio will happen, which may result in engine performance reduce. If some solids come into engine combustion, death damage to the engine will happen.

### CAUTION

The air filter is a critical emission related component and should not be altered or modified in any way.

Operating engine with loose or damaged air cleaner components could cause engine wear and failure, and valid your warranty.

Paper element cannot be blown out with compressed air.

### WARNING

Do not run the engine when the air filter is not installed; otherwise, this may cause damage to the engine.

### DANGER

Do not use the gasoline or the cleaning agent with low ignition point to clean the air filter element; Otherwise, this may result in a fire or cause an explosion.

## Spark plug

- 1.Recommended spark plug: F6RTC or equivalent.
- 2.The non-recommended spark plug may cause damage to the gasoline engine.
- 3.Remove the dirt from the spark plug cap and bottom.
- 4.Remove the spark plug cap.
- 5.Using socket wrench to loose and remove the spark plug.
- 6.Inspect the spark plug and spark plug washer, if it's damaged or worn, replace with new one. Clean the spark plug with wire brush if reuse it.
- 7.Check spark plug gap. Carefully bend side electrode to adjust the gap if necessary.

## Spark plug gap:

**0.6mm - 0.8mm**

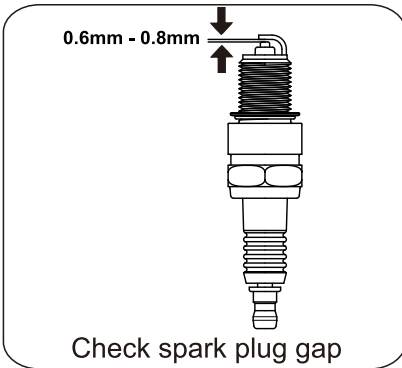

8. Carefully thread the plug into the engine **by hand**.

9. After the spark plug is seated, use spark plug wrench to tighten the plug.

**Spark Plug tighten Torque:  
20-25 N.m**

10. Attach the spark plug wire to the plug.

### **⚠ WARNING**

Only use recommended spark plug or equivalent. **DO NOT** use spark plugs that have improper heat range.

The spark plug must be tightened, and if it is loosened, the combustion chamber will not be sealed tightly when the gasoline engine runs, the compressed air leaks will reduce the power of the gasoline engine and a serious leak will cause that the gasoline engine cannot be started.

To ensure the normal operation of the gasoline engine, the spark plug gap must be moderate without deposits. Clean and adjust the spark plug according to the steps shown.

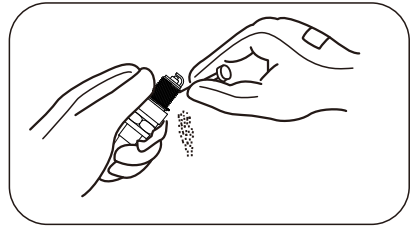

- a) Remove the spark plug
- b) Remove carbon deposits

## Spark Arrester

(Applicable types)

1. Allow the engine to cool completely before servicing the spark arrester.

2. Remove the two screws holding the cover plate which retains the end of the spark arrester to the muffler.

3. Remove the spark arrester screen.

4. Carefully remove the carbon deposits from the spark arrester screen with a wire brush.

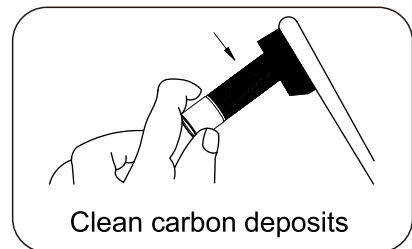

5. Replace the spark arrester if it is damaged.

6. Reinstall the spark arrester in the muffler and attach with the two screws.

### **Adjusting the valve clearance**

Each gasoline engine is debugged and inspected strictly by the company in the factory. Generally, the machine can work properly without any adjustments. After use for some time, you may need to adjust the gasoline engine with the adjustment method as follows:

1. Rotate flywheel to timing point, and hold the valve clearance adjusting nut, then release the valve locking nut.



#### **WARNING**

Unauthorized modification may cause damage to the engine and void the warranty.

2. Rotate the valve clearance adjusting nut to a predetermined clearance.

3. Hold the valve clearance adjusting nut and tighten the valve locking nut according to the predetermined torque.

4. Tighten the valve locking nut, and then check the valve clearance again until the valve clearance is in line with the standard.

### **3. Idle Speed**

The idle speed has been pre-set at the factory and should rarely require readjustment. Consult your local authorized dealer for such needs.

### **4. Adjustment**

No other service and/or adjustment is needed for your engine.

Unapproved adjustments or tampering can damage your engine and your electrical devices and will void your warranty. Contact your local dealer for such needs.

## V. Trouble analysis and trouble-shooting

Phenomenon	Problems	Solutions
Engine Cannot be started	Engine switch is off.	Turn engine switch to the <b>ON</b> position.
	There is no fuel	Fill tank per instructions in this manual.
	Inadequate engine oil.	Check oil level. This engine is equipped with a low oil sensor. The engine cannot be started unless the oil level is above the prescribed lower limit.
	There is no ignition	Remove the spark plug cap. Clean any dirt around the plug base, then remove the spark plug. Install the spark plug in the plug cap. Turn the engine switch on. Grounding the electrode to any engine ground, pull the recoil starter to see if sparks jump across the gap. If there is no spark, replace the plug. Reinstall the plug and start engine according to instructions in this manual. Consult Customer Service.

## VI. Storage

DO NOT mix oil with gasoline. The engine should be started at least once every 2 weeks and allowed to run for at least 20 minutes. Follow the instructions below for longer term storage if the engine were out of service for 2 months or more.



**⚠ DANGER**

### **Fire or explosion**

Gasoline is highly flammable and extremely explosive. Empty the fuel tank and shut off fuel valve before storing or transporting this engine.

1. Change oil while engine is still warm from operation.
2. Allow the engine to cool completely.
3. Drain all fuel completely from the fuel tank, fuel hose and carburetor.
4. Remove spark plug and pour about 1 oz. of engine oil into cylinder. Reinstall spark plug. Crank engine slowly to distribute oil and lubricate cylinder.
5. Clean the engine according to the instructions in the Maintenance section.
6. Store the unit in a clean, dry area out of direct sunlight.

# VII. Specification

## 1. Specification Parameter Table

### Main structure parameters

Air valve arrangement	overhead valve
Number of air cylinders	2
Air cylinder diameter (mm)	78
Piston stroke (mm)	71
Total displacement (cm <sup>3</sup> )	679
Compression ratio	8.5:1
Maximum power (kW/min <sup>-1</sup> )	14.5/3600
Direction of rotation	anticlockwise (from the flywheel end direction)
Ignition timing (°)	25° ± 2°
Intake valve clearance (mm)	0.10 ~ 0.15
Exhaust valve clearance (mm)	0.15 ~ 0.20
Spark gap (mm)	0.6 ~ 0.8

### Fuel and lubricating oil

Lubricating oil brand	SAE 10W/30 (GB 11121-2006)
Fuel supplier	carburetor oil supply
Lubricating oil capacity (ml)	2000

### Dimension and mass

Length × width × height (mm)	465×457×395
Net mass (excluding oil, water and chassis) (kg)	49.6

**Notes: The gasoline engine with different specification and configurations may have different parameters and may change at any time without notice.**



## 2. Engine dimension

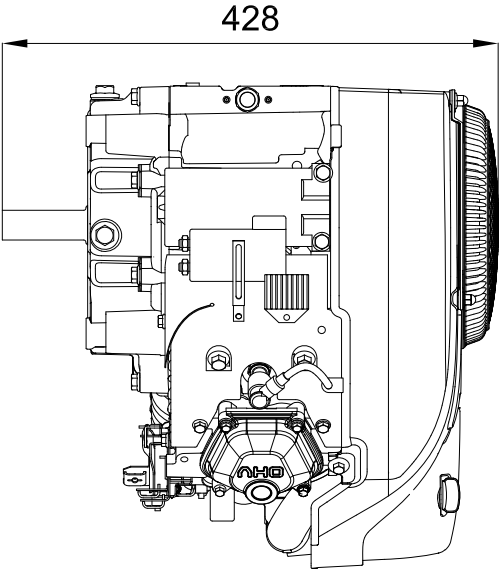
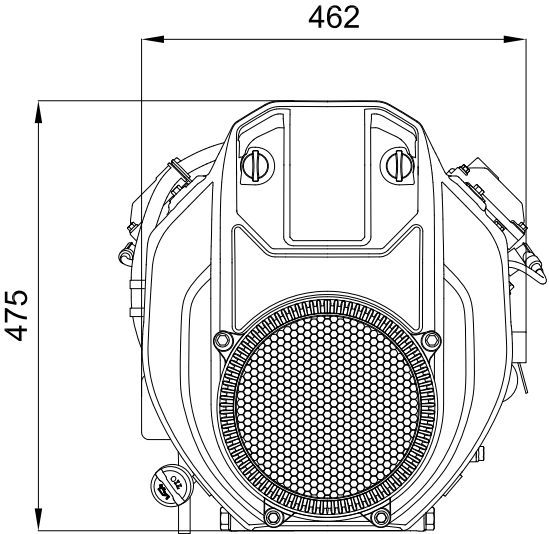

### 3. Engine circuit diagram.

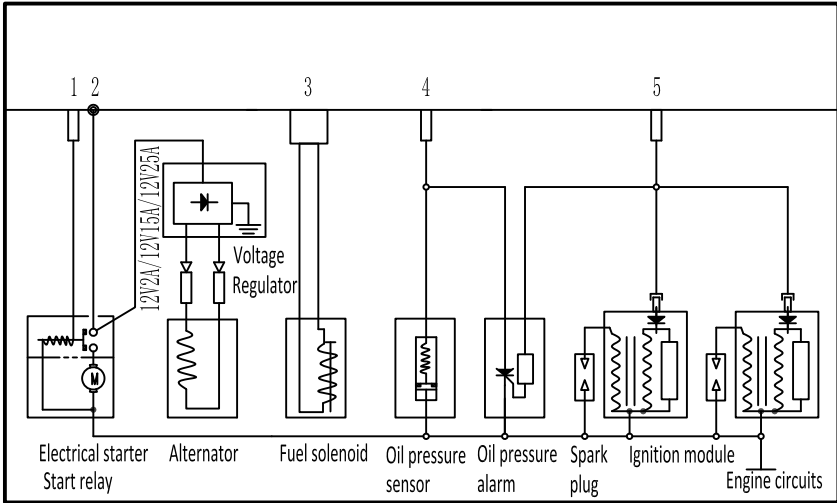

Terminal No.	Terminal of engine (recommended)	Terminal of application(recommended)	Terminal	Memo
1	DJ6211-D6.3×0.8	DJ6211-J6.3AX0.8 or equivalent	Start relay terminal	
2	Bolt M8	Y8-10 or equivalent	Electrical power terminal	
3	DJ7021A-2.8-21	DJ7021A-2.8-11	Fuel solenoid power terminal	Dual-wire
	DJ211-4A	DJ221-4A		Sole-wire, positive pole for e-power
4	DJ6211-D6.3×0.8	DJ6211-J6.3AX0.8 or equivalent	Oil pressure low potential signal terminal	
5	DJ221-4A	DJ211-4A	Engine shut off terminal	

**Note:** 1 Oil pressure sensor and oil pressure alarm are optional.

1.1 If equipped with both oil pressure sensor and oil pressure alarm, the original set should be shut off in low oil pressure, without terminal 4.

1.2 If only equipped with oil pressure sensor, the original set should have signal output in low oil pressure, with terminal 4.

2 Output e-power is suitable for 2A, 15A, or 25A.

3 Fuel solenoid control harness is suitable for sole or dual wire.





**CHONGQING ZONGSHEN GENERAL POWER MACHINE CO., LTD.**

Address: Zongshen Industry Zone, Ba'nán District, Chongqing, 400054, China

Phone: 0086-23-66372525

Hot Line: 0086-4001696444    0086-23-66372519    0086-23-66372096

Engine Production License NO.: XK06-002-00655

<http://www.zongshenpower.com>

1001#/V1.2